



SIRIUS safety relay Input expansion Advanced Input expansion for an additional 2-channel or two 1-channel sensors $U_s = 24\text{ V DC}$ screw terminal

product brand name	SIRIUS
product category	Safety relays
product designation	Sensor extension
product type designation	3SK1
Product Function	
product function parameterizable	sensor floating / sensor non-floating, monitored start-up / automatic start, 1-channel / 2-channel sensor connection, cross-circuit detection, startup testing, antivalent sensors, 2-hand switches
product function	
<ul style="list-style-type: none"> • automatic start • light barrier monitoring • protective door monitoring • magnetically operated switch monitoring NC-NO • magnetically operated switch monitoring NC-NC • laser scanner monitoring • light array monitoring • EMERGENCY OFF function • monitored start-up • pressure-sensitive mat monitoring 	<ul style="list-style-type: none"> Yes Yes Yes Yes Yes Yes Yes Yes Yes No
suitability for interaction press control	No
suitability for use	
<ul style="list-style-type: none"> • monitoring of floating sensors • monitoring of non-floating sensors • position switch monitoring • EMERGENCY-OFF circuit monitoring • opto-electronic protection device monitoring • magnetically operated switch monitoring • safety switch • safety-related circuits 	<ul style="list-style-type: none"> Yes Yes Yes Yes Yes Yes Yes Yes
General technical data	
certificate of suitability UL approval	Yes
product feature cross-circuit-proof	Yes
power loss [W] maximum	1.2 W
insulation voltage rated value	50 V
degree of pollution	3
overvoltage category	3
surge voltage resistance rated value	800 V
protection class IP of the enclosure	IP20
shock resistance	10g / 11 ms
vibration resistance according to IEC 60068-2-6	5 ... 500 Hz: 0.75 mm
reference code according to IEC 81346-2	F

Substance Prohibitance (Date)	11/05/2012
SVHC substance name	Lead - 7439-92-1 Lead monoxide (lead oxide) - 1317-36-8 2,2',6,6'-tetrabromo-4,4'-isopropylidenediphenol - 79-94-7 2-methyl-1-(4-methylthiophenyl)-2-morpholinopropan-1-one - 71868-10-5 6,6'-di-tert-butyl-2,2'-methylenedi-p-cresol - 119-47-1 Lead titanium zirconium oxide - 12626-81-2
Weight	0.16 kg
Ambient conditions	
installation altitude at height above sea level maximum	4 000 m; Derating, see Product Notification 109792701
ambient temperature	
• during operation	-25 ... +60 °C
• during storage	-40 ... +80 °C
relative humidity during operation	10 ... 95 %
air pressure according to SN 31205	900 ... 1 060 hPa
Electromagnetic compatibility	
installation environment regarding EMC	This product is suitable for Class A environments only. In household environments, this device can cause unwanted radio interference. The user is required to implement appropriate measures in this case.
EMC emitted interference	IEC 60947-5-1, Class A
Safety related data	
product function suitable for safety function	Yes
safe state	Safety outputs switched off
test wear-related service life necessary	No
function test interval maximum	1 a
diagnostics test interval by internal test function maximum	600 s
stop category according to IEC 60204-1	0
IEC 62061	
SIL Claim Limit (subsystem) according to EN 62061	3
Safety Integrity Level (SIL)	
• according to IEC 62061	SIL 3
• at 2-channel evaluation according to IEC 62061	3
PFHD with high demand rate according to IEC 62061	1E-9 1/h
ISO 13849	
category according to EN ISO 13849-1	4
performance level (PL)	
• according to ISO 13849-1	PL e
• at 2-channel evaluation according to ISO 13849-1	e
category	
• according to ISO 13849-1	4
• at 2-channel evaluation according to ISO 13849-1	4
device type according to ISO 13849-1	1
IEC 61508	
Safety Integrity Level (SIL)	
• according to IEC 61508	3
• at single-channel evaluation according to IEC 61508	1
• at 2-channel evaluation according to IEC 61508	3
safety device type according to IEC 61508-2	Type B
PFHD with high demand rate according to IEC 61508	1E-9 1/h
Average probability of failure on demand (PFDavg) with low demand rate acc. to IEC 61508	7E-6 1/y
PFDavg with low demand rate according to IEC 61508	7E-6
Safe failure fraction (SFF)	99 %
hardware fault tolerance	
• according to IEC 61508	1
• at single-channel evaluation according to IEC 61508	0
• at 2-channel evaluation according to IEC 61508	1
T1 value	
• of service life according to IEC 61508	20 a
• for proof test interval or service life according to IEC 61508	20 a
Electrical Safety	
touch protection against electrical shock	finger-safe

Inputs	
design of input	
• feedback input	No
• start input	Yes
number of sensor inputs 1-channel or 2-channel	1
Outputs	
number of outputs as contact-affected switching element	
• as NC contact	
— for signaling function instantaneous contact	0
— for signaling function delayed switching	0
— safety-related instantaneous contact	0
— safety-related delayed switching	0
• as NO contact	
— for signaling function instantaneous contact	0
— for signaling function delayed switching	0
— safety-related instantaneous contact	0
— safety-related delayed switching	0
number of outputs as contact-less semiconductor switching element	
• for signaling function	
— delayed switching	0
wire length between sensor and electronics evaluation device with Cu 1.5 mm ² and 150 nF/km maximum	4 000 m
Times	
make time with automatic start	
• typical	60 ms
• at DC maximum	60 ms
make time with automatic start after power failure	
• typical	6 500 ms
• maximum	6 500 ms
make time with monitored start	
• typical	60 ms
• maximum	60 ms
backslide delay time after opening of the safety circuits typical	40 ms
recovery time after opening of the safety circuits typical	30 ms
pulse duration	
• of the sensor input minimum	60 ms
• of the ON pushbutton input minimum	0.15 s
Control circuit/ Control	
type of voltage of the control supply voltage	DC
control supply voltage at DC rated value	24 V
operating range factor control supply voltage rated value of magnet coil at DC	
• initial value	0.8
• full-scale value	1.2
Installation/ mounting/ dimensions	
mounting position	any
fastening method	screw and snap-on mounting
height	100 mm
width	17.5 mm
depth	121.6 mm
required spacing	
• with side-by-side mounting at the side	0 mm
• for grounded parts at the side	5 mm
Connections/ Terminals	
type of electrical connection	screw terminal
type of connectable conductor cross-sections	
• solid	1x (0.5 ... 2.5 mm ²), 2x (1.0 ... 1.5 mm ²)
• finely stranded with core end processing	1x (0.5 ... 2.5 mm ²), 2x (0.5 ... 1.0 mm ²)
• for AWG cables solid	1x (20 ... 14), 2x (18 ... 16)
type of electrical connection plug-in socket	No

Approvals Certificates

General Product Approval

EMV



Functional Safety

Test Certificates

Marine / Shipping

[Type Examination Certificate](#)

[Type Test Certificates/Test Report](#)



other

Railway

Environment

[Confirmation](#)

[Confirmation](#)

[Environmental Confirmations](#)

Further information

Information on the packaging

<https://support.industry.siemens.com/cs/ww/en/view/109813875>

Information- and Downloadcenter (Catalogs, Brochures,...)

<https://www.siemens.com/ic10>

Industry Mall (Online ordering system)

<https://mall.industry.siemens.com/mall/en/en/Catalog/product?mlfb=3SK1220-1AB40>

Cax online generator

<http://support.automation.siemens.com/WWW/CAXorder/default.aspx?lang=en&mlfb=3SK1220-1AB40>

Service&Support (Manuals, Certificates, Characteristics, FAQs,...)

<https://support.industry.siemens.com/cs/ww/en/ps/3SK1220-1AB40>

Image database (product images, 2D dimension drawings, 3D models, device circuit diagrams, EPLAN macros, ...)

http://www.automation.siemens.com/bilddb/cax_de.aspx?mlfb=3SK1220-1AB40&lang=en

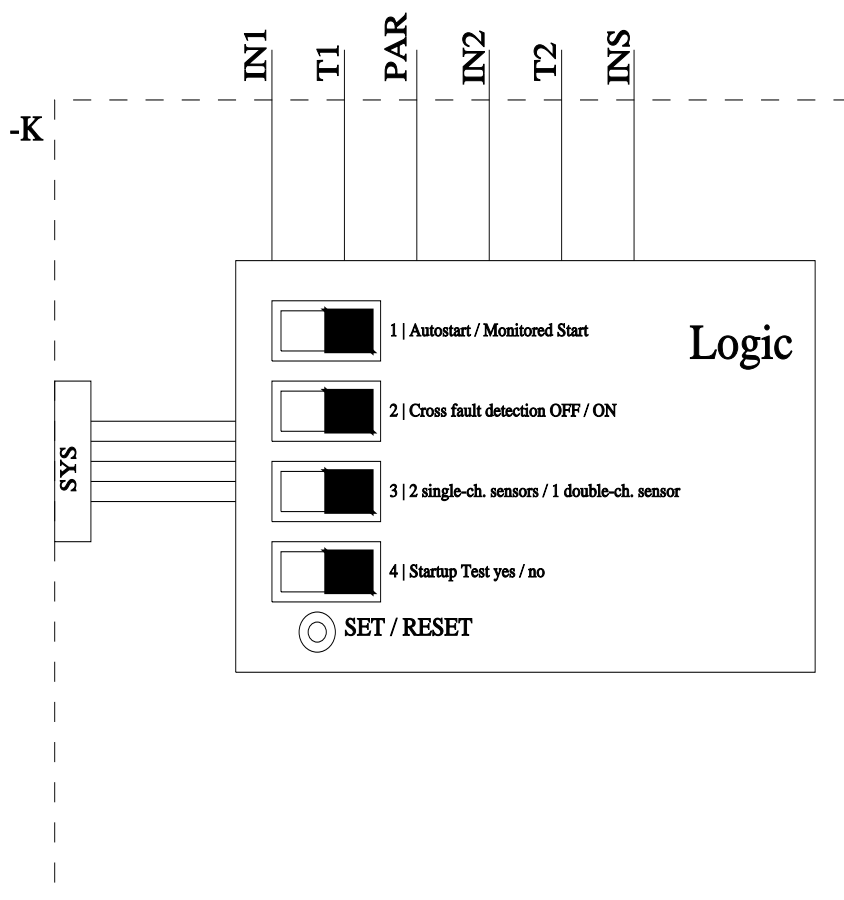
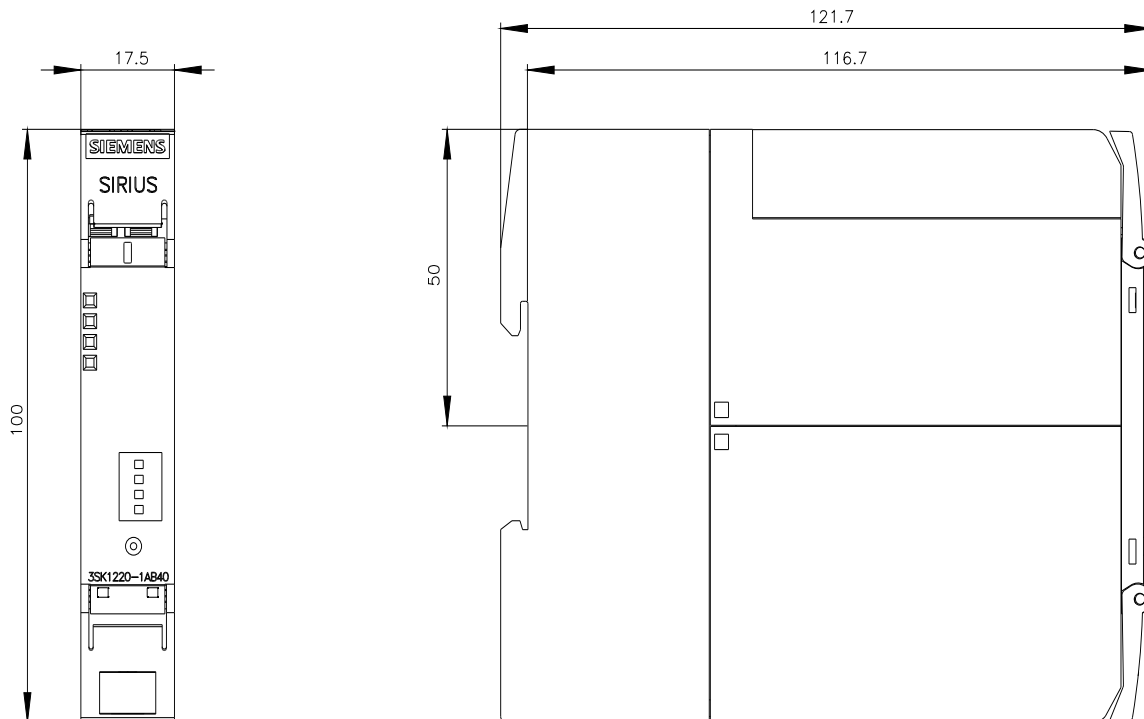

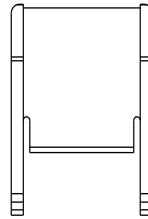
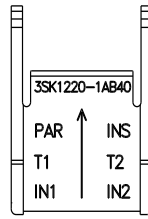
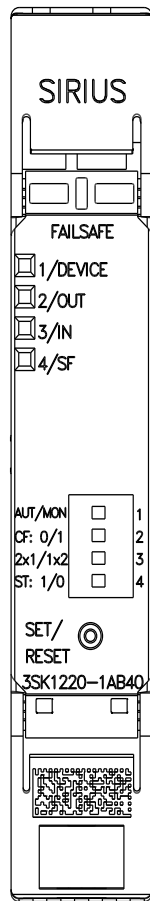

last modified:

4/2/2025 