

MGB-L1-APA-AH2A1-S1-L-115887 (Order no. 115887)

Locking module MGB-L1-APA... (guard locking by spring force) with 1 indicator, RC18

- ▶ Guard locking with guard lock monitoring
- ▶ 1 indicator (illuminated, gn)
- ▶ With plug connector RC18
- ▶ Unicode

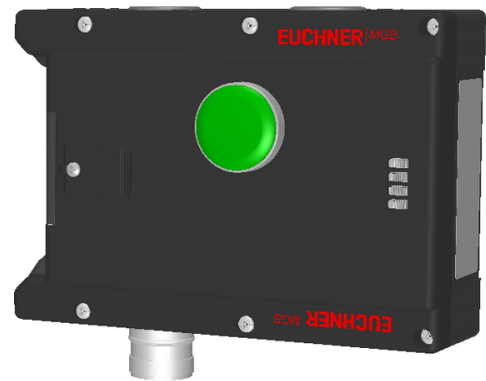

Guard locking type

MGB- The locking arm is held in the locked position by spring force and is unlocked by solenoid force
L1... (closed-circuit current principle, mechanically locked).

Door hinge

A mechanical door stop is permanently integrated into the evaluation module of the MGB. A marking on the stop makes adjustment easier.

LED indicator

The LED indicator indicates all important system and status information.

Monitoring outputs

OT Bolt tongue inserted into the evaluation module

OI Diagnostics; there is a fault

Indicators

H2 LED, green

Dimensional drawings

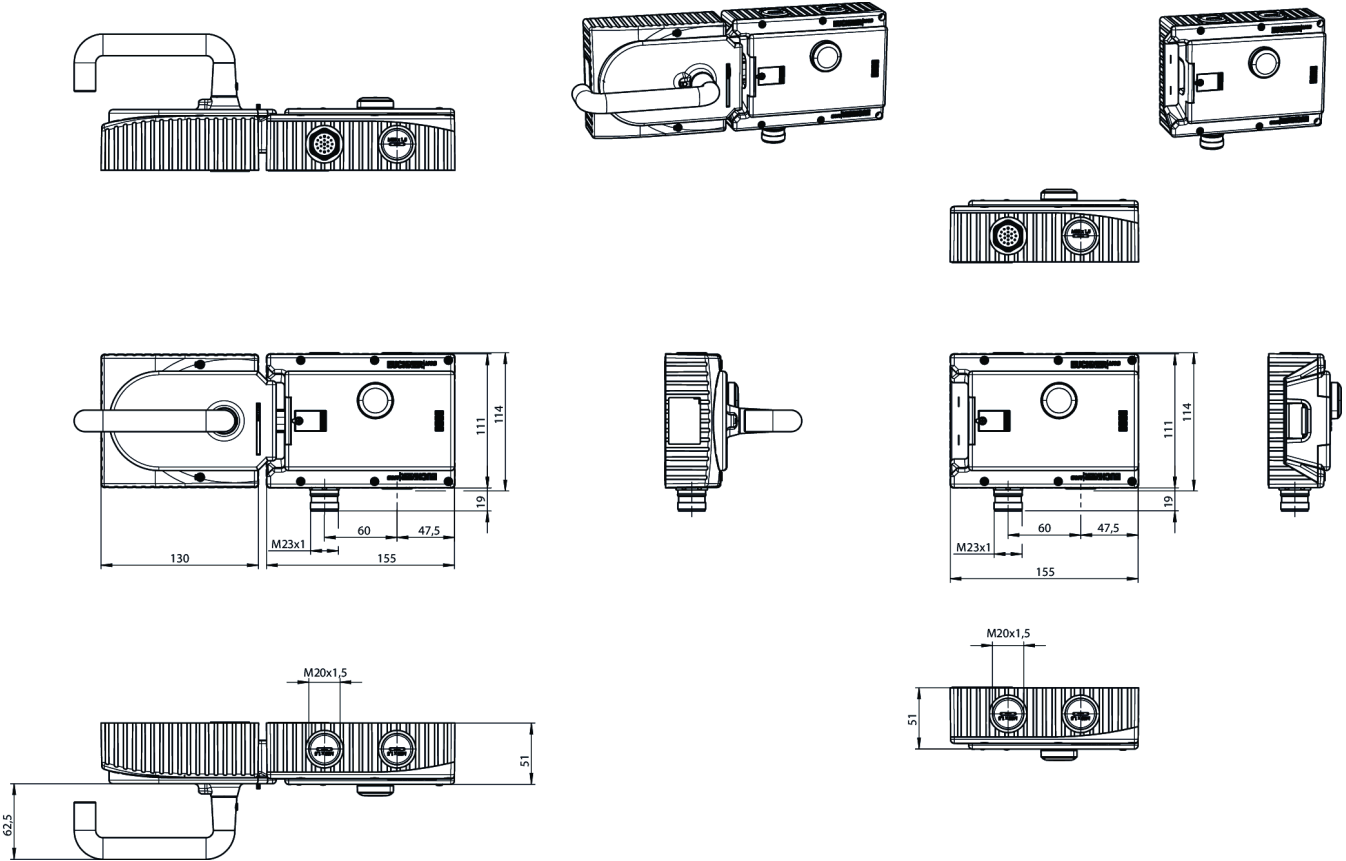

Dimensional drawings

