

CIT3ASX1R1G05KX (Order no. 077890)

Read/write head CIT3A G05 with serial interface



Serial interface

The individual commands for reading and writing the data carrier are in accordance with the common 3964R protocol and are described in the EUCHNER CIS3 system manual (order no. 071 652). For data carrier programming away from the system, a convenient WINDOWS[®]-compatible PC software application is available (Software Transponder Coding).

Standard housing

The size of the robust housing in degree of protection IP65 is compliant with the standard EN 50041. The division into 3 assemblies permits easy mounting and straightforward replacement.

Attention:

On the use of a screened cable the connecting cable for the serial interface is allowed to be max. 5 m long.

Dimensional drawings

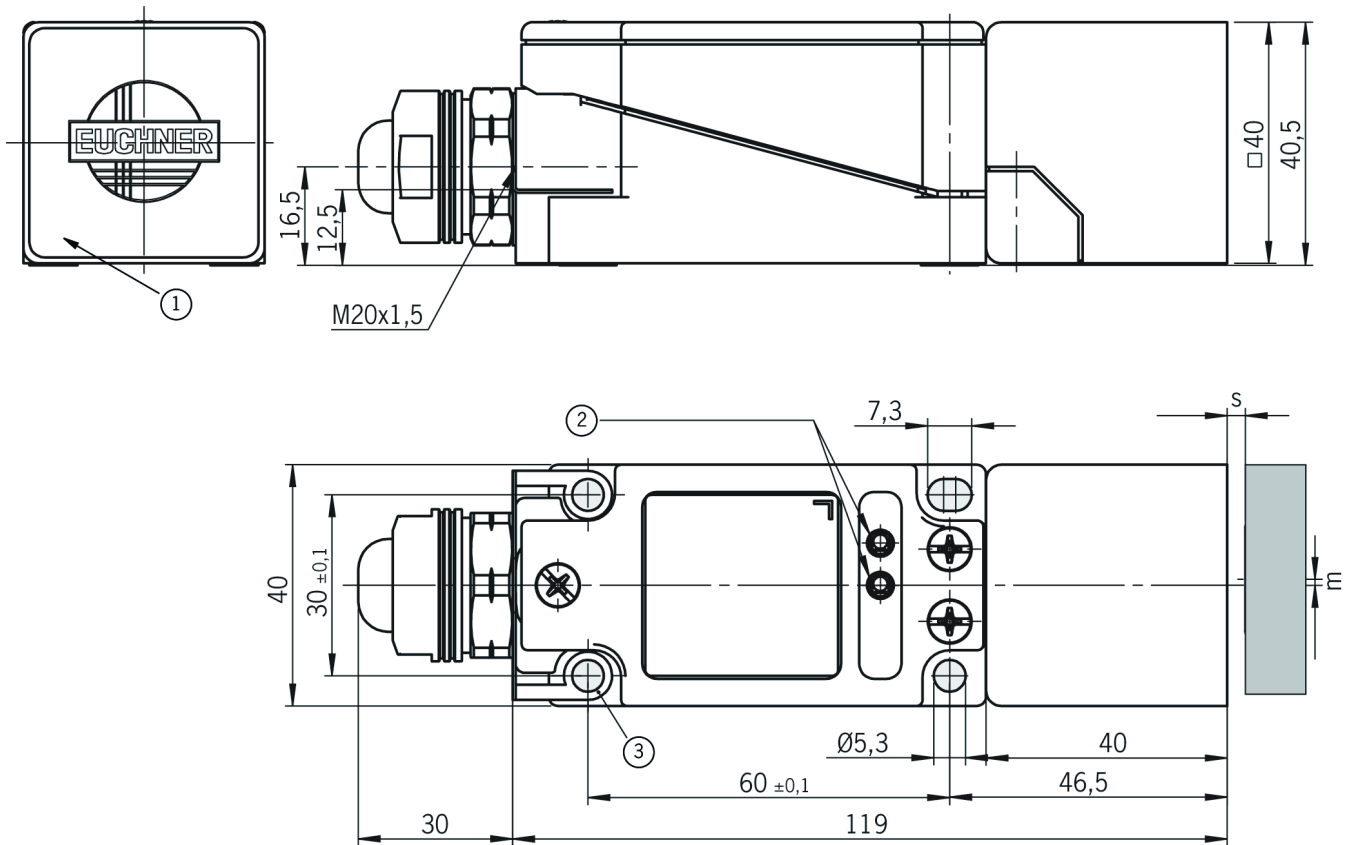

- 1 Active face
- 2 LED status indication
- 3 shield spring
- m Center offset
- s Read distance

Connection examples

Klemme	Bezeichnung	Beschreibung
1	24 V/U _B	Spannungsversorgung, DC 24 V
2	RxD	Serielle Schnittstelle Empfangen
3	0V/GND	Masse, DC 0 V
4	TxD	Serielle Schnittstelle Senden

Technical data

Operating and display elements

LED display

green	operational
yellow	Data carrier in actuating range

Electrical connection values

Operating voltage DC	20 ... 24 ... 28 V DC (All the electrical connections must either be isolated from the mains supply by a safety transformer according IEC/ EN 61558-2-6 with limited output voltage in the event of a fault, or by other equivalent isolation measures.)
Current consumption	max. 140 mA

Mechanical values and environment

Connection type	Screw terminal
Storage temperature	-25 ... 70 °C
Cable length	max. 5 m for RS232
Degree of protection	IP65
Ambient temperature	0 ... 55 °C
Material	
	Housing Plastic

Interface

Data protocol	3964R via RS232 8 data bits, even parity
Data rate	9,6 kbit/s
Date interface	RS232

In combination with actuator CIS3AP50X50SH16YSNOU, CIS3AP50X50SH16YSNOP

Read distance	
	at 25 °C 0 ... 20 ... 28 mm
Center offset	
	at 25 °C, s = 20 mm read distance -13 ... 13 mm