

MGB-L2-ARA-BM5A1-S1-R-121179 (Order no. 121179)

Locking module MGB-L2-ARA... (guard locking by solenoid force) with 2 pushbuttons, emergency stop, incl. label carrier, RC18

- ▶ Guard locking with guard lock monitoring (switched off)
- ▶ Can be connected in series with other AR devices (e.g. CES-AR and CET-AR)
- ▶ Emergency stop according to ISO 13850
- ▶ 2 pushbuttons (illuminated)
- ▶ With lens set, 6 pcs.
- ▶ incl. adhesive labels
- ▶ With plug connector RC18
- ▶ Unicode

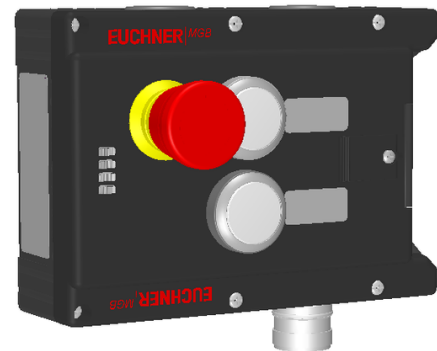

Guard locking type

MGB-L2... The locking arm is held in the locked position by solenoid force and is unlocked by spring force when the solenoid is switched off (open-circuit current principle, electrically locked).

Guard lock monitoring switched off

As the default setting on delivery, guard lock monitoring is switched off via the internal DIP switches on these evaluation modules. Consequently, the guard locking is suitable only for process protection. Safety outputs FO1A and FO1B do not depend on the state of guard locking.

Door hinge

A mechanical door stop is permanently integrated into the evaluation module of the MGB. A marking on the stop makes adjustment easier.

LED indicator

The LED indicator indicates all important system and status information.

Monitoring outputs

OT Bolt tongue inserted into the evaluation module

OI Diagnostics; there is a fault

Emergency stop device

S1 2 positively driven contacts, emergency stop with turn-to-reset, not illuminated

Pushbuttons

S2 1 NO contact, illuminated

S3 1 NO contact, illuminated

Lens set

The color of the pushbuttons can be selected using the color cover set included (5 colors). Item no.: 120344 (see Accessories)

Adhesive labels

Devices with adhesive labels have pre-formed recesses. The adhesive labels enclosed (standard size 12.5 x 27 mm) can be affixed in these recesses.

Dimensional drawings

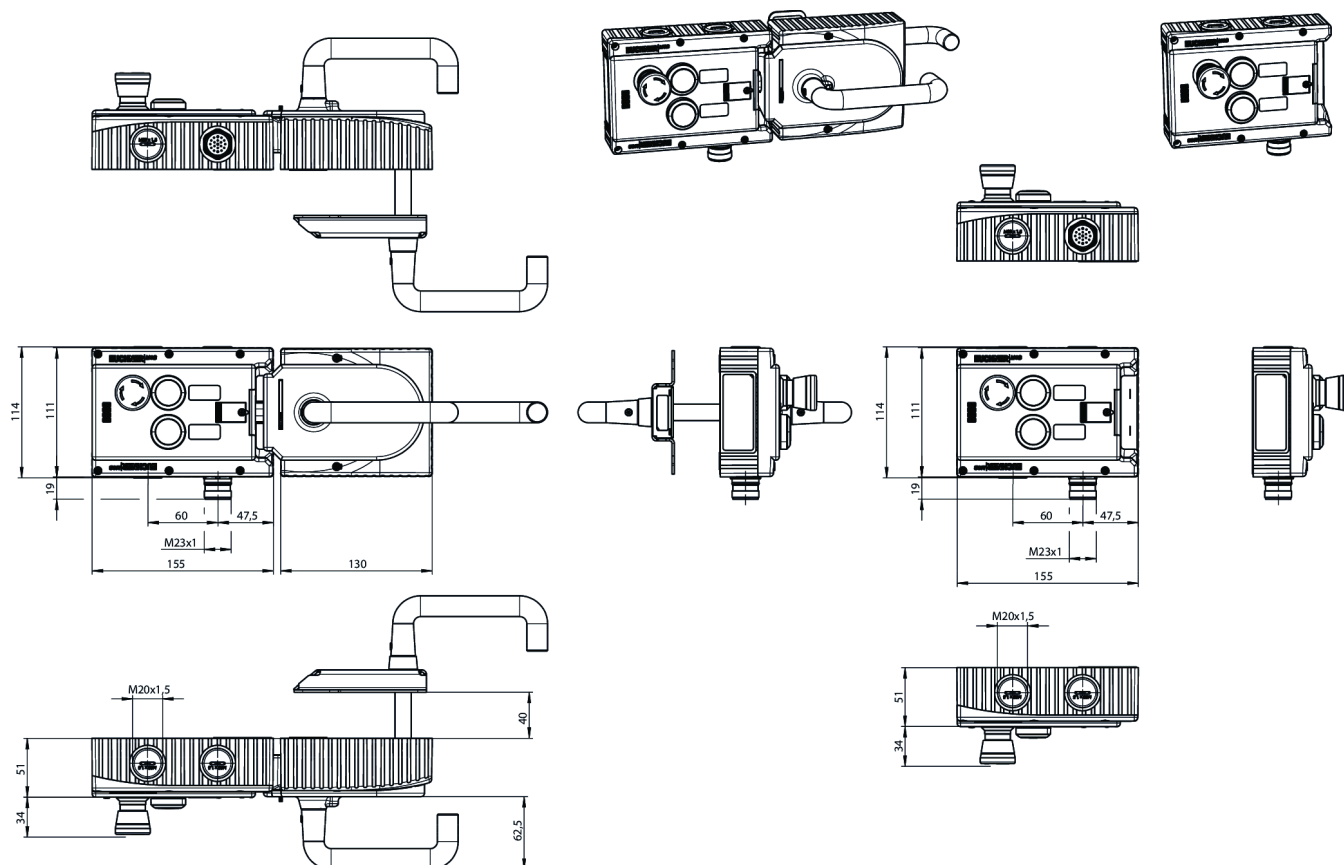

Dimensional drawings

