

NZ2HB-511SVM5L060GE (Order no. 098649)

Safety switch NZ.HB, lever arm with plastic roller, plug connector M12

- ▶ Lever arm, plastic roller \varnothing 18 mm
- ▶ Version A according to EN 50041
- ▶ Plug connector M12, 5-pin
- ▶ 1 pos. driven contact
- ▶ 1 NO contacts
- ▶ LED indicator: AC/DC 12-60 V yellow



Approach direction



Horizontal

Can be adjusted in 90° steps

Switching direction adjustable

Right, left or both sides

LED indicator

The switch has one freely assignable LED indicator.

Switching element

511 Snap-action switching contact, 1 positively driven contact $\ominus \rightarrow$ + 1 NO contact

Dimensional drawings

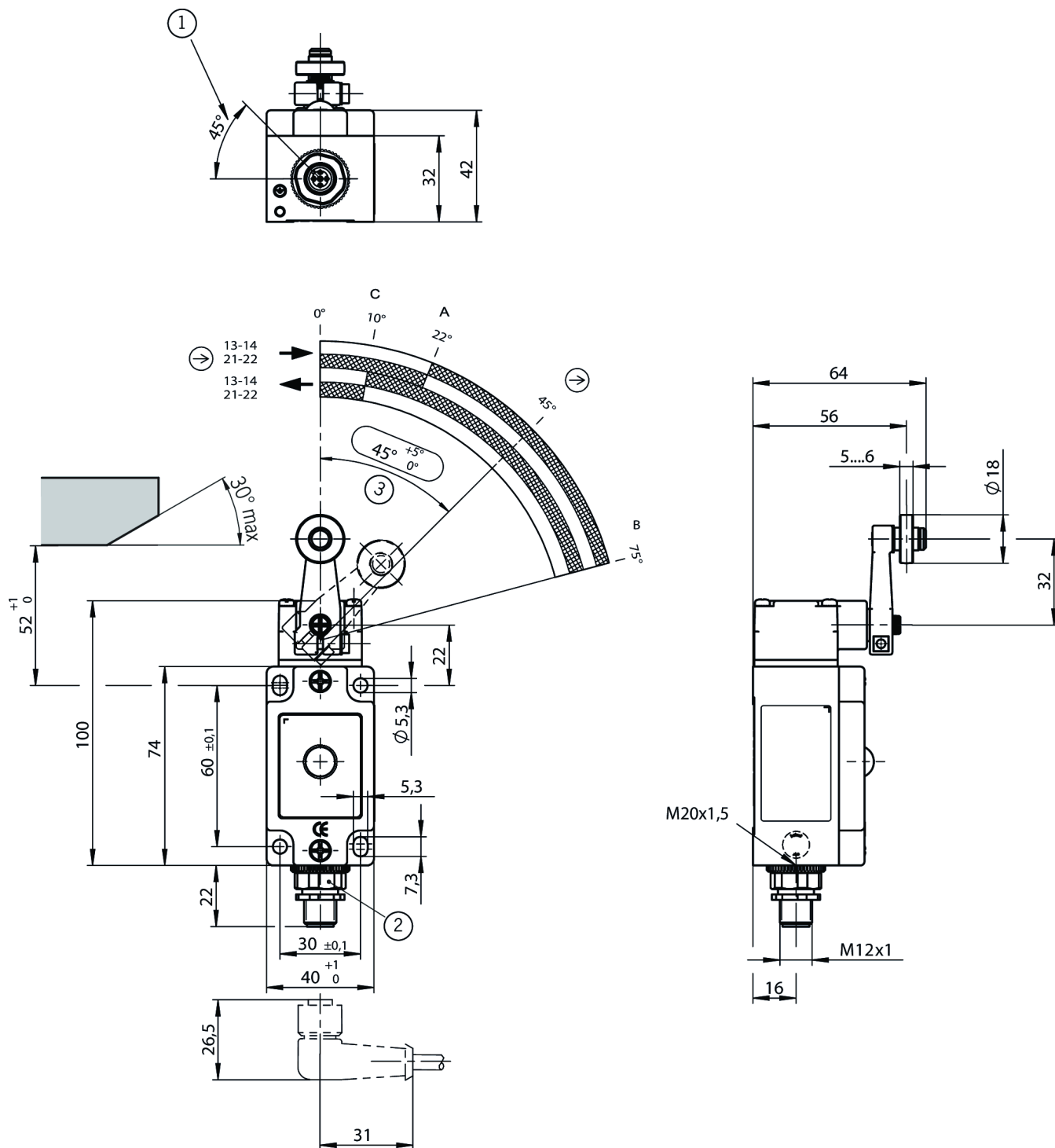

1 Guide lug aligned

2 Male socket adjustable (max. 270°)

3 Positive opening function is dependent on maintaining this distance. Actuator (dog) must be positively mounted on the machine. Switch can be replaced only with the same type.

A Operating point

B End position

C Reset point

Connection examples

