

NM02VZA-M (Order no. 084453)

Safety switch NM.VZ, long housing, cable entry M16 x 1.5

- ▶ 3x cable entry M16 x 1.5
- ▶ 2 pos. driven contact



Approach direction

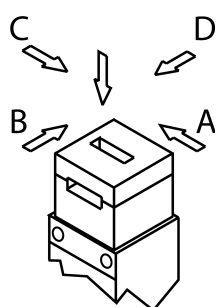

Horizontal and vertical
Can be adjusted in 90° steps

Switching element

ES02 Slow-action switching contact 2 positively driven contacts (→)

Accessories required

Actuator is not included.

Dimensional drawings

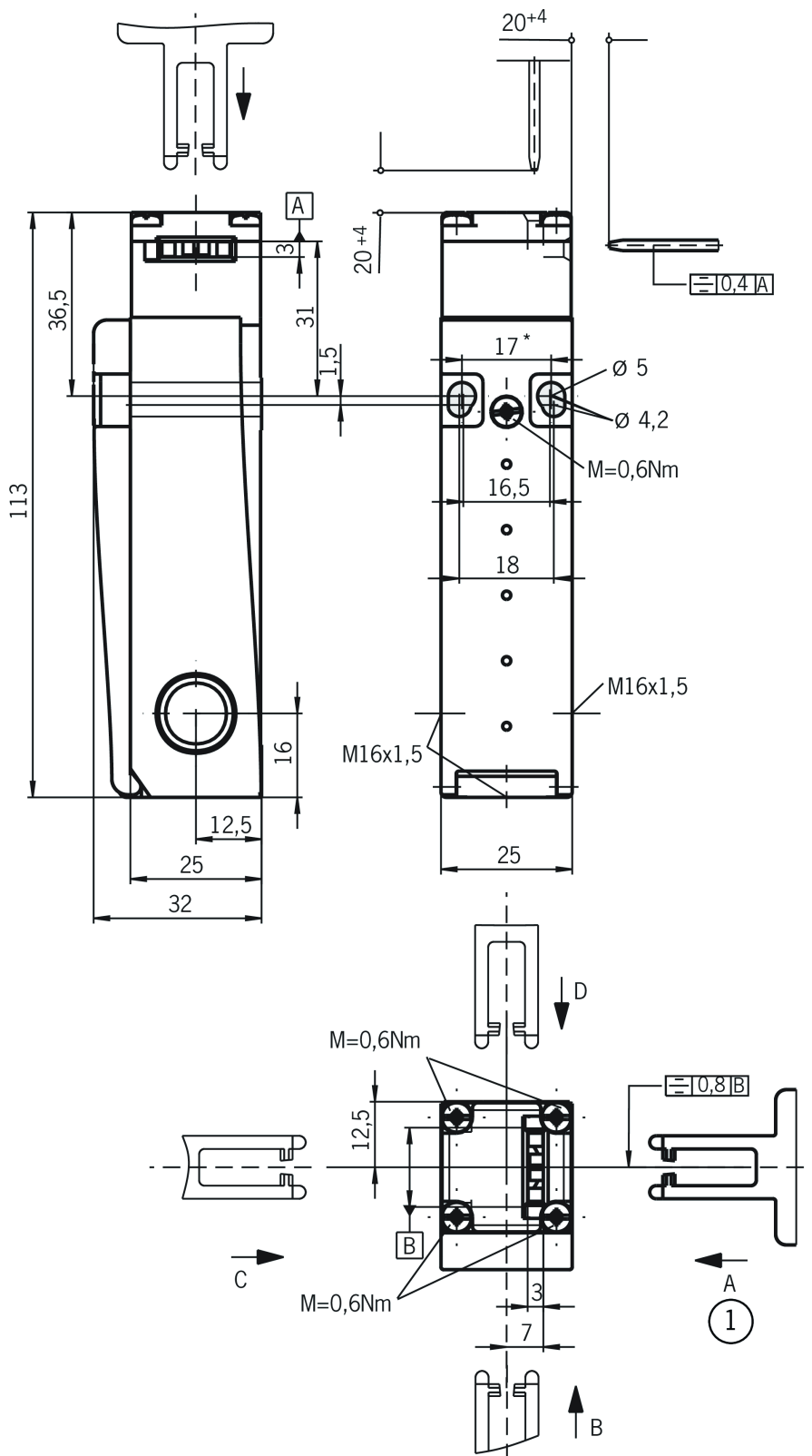

* fixed positioning for safety-related applications (M5)

1 Standard

Connection examples

