

MSM-1-P-CA-BPP-E2-162930 (Order no. 162930)

Submodule MSM-1-P... (illuminated emergency stop, 2 illuminated blue pushbuttons with symbol)

- ▶ Function expansion for modules MGB2 and MCM
- ▶ Connection type: P
- ▶ 1 illuminated emergency stop according to ISO 13850
- ▶ 2 illuminated blue pushbuttons with symbol



Dimensional drawings

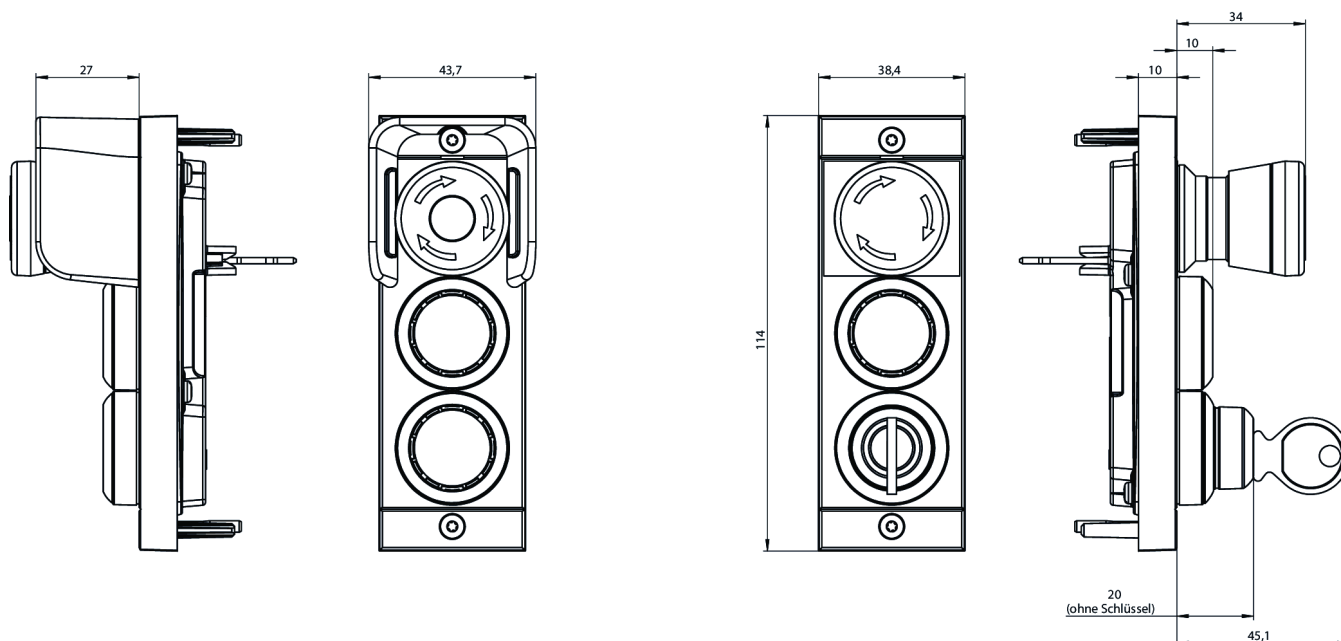

Dimensional drawings

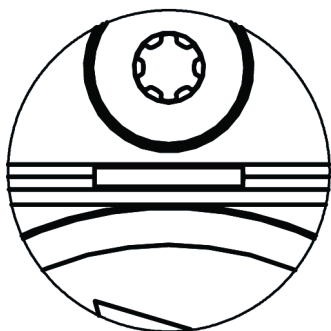

Z 2:1

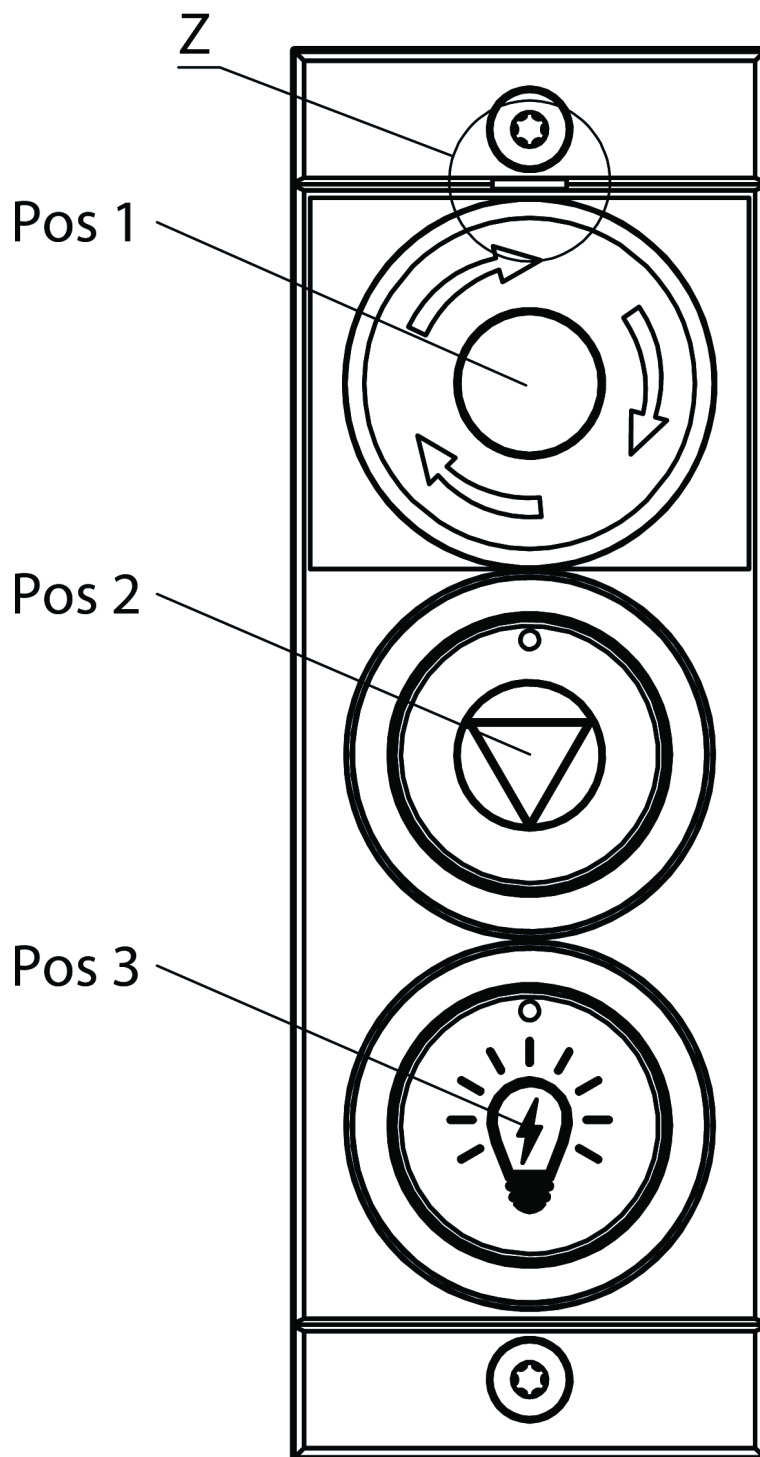

Pos 1 Emergency stop according to ISO 13850, illuminated

Pos 2 illuminated pushbutton, blue

Pos 3 illuminated pushbutton, blue

Z marks orientation of item 1

Connection examples

