



Built-in V-series Miniature Basic Switch for Compatibility with Business and Consumer Equipment

- Momentary operation and lock.
- Operation Unit available in six colors.
- Improved sense of touch with built-in miniature basic switch.



 Refer to *Safety Precautions for All Pushbutton Switches/ Indicators* and *Safety Precautions* on page 4.

Ordering Information

Classification	Shape of Operation Unit	Output	Operation Unit color					
			Blue (-A)	Black (-B)	Green (-G)	Red (-R)	White (-W)	Yellow (-Y)
Momentary operation		1 *1	VAQ-4A-K	VAQ-4B-K	VAQ-4G-K	VAQ-4R-K	VAQ-4W-K	VAQ-4Y-K
		1 *2	VAQ-4A-L	VAQ-4B-L	VAQ-4G-L	VAQ-4R-L	VAQ-4W-L	VAQ-4Y-L
		2 *2	2VAQ-4A	2VAQ-4B	2VAQ-4G	2VAQ-4R	2VAQ-4W	2VAQ-4Y
Lock		1 *2	—	VAQR-4B	VAQR-4G	VAQR-4R	VAQR-4W	—

*1. The Operation Unit can be inserted and removed.

*2. The Operation Unit is screwed in.

Specifications

Ratings

Item	Rated voltage (V)	Non-inductive load (A)		Inductive load (A)	
		Resistive load	Lamp load	Inductive load	Motor load
Built-in Switch	125 VAC	15	2	10	3
	250 VAC	15	2	10	3
	8 VDC	15	4	10	6
	30 VDC	10	4	10	4
	125 VDC	0.6	0.1	0.6	0.1
	250 VDC	0.3	0.05	0.3	0.05

Note: 1. The above values are for steady-state currents.

2. Inductive load: Power factor = 0.4 (AC); time constant = 7 ms (DC).

3. The lamp load has an inrush current of 10 times the steady-state current.

4. The motor load has an inrush current of 6 times the steady-state current.

5. The rated values above are for testing conducted under the following conditions.

(1) Ambient temperature: 20 ± 2°C.

(2) Ambient humidity: 65% ± 5%RH

(3) Operating frequency: 20 times/min.

Specifications

Characteristics

Operating frequency	Mechanical	120 operations/min
	Electrical	20 operations/min
Insulation resistance		100 MΩ min. (at 500 VDC)
Contact resistance		30 mΩ max. (initial value)
Dielectric strength	Between terminals of same polarity	1,000 VAC, 50/60 Hz for 1 minute
	Between current-carrying metal part and ground, and between each terminal and non-current-carrying metal part	1,500 VAC, 50/60 Hz for 1 minute
Vibration resistance	Malfunction	10 to 55 Hz, 1.5 mm double amplitude *
Shock resistance	Destruction	500 m/s ² max.
	Malfunction	200 m/s ² max. *
Durability	Mechanical	3,000,000 operations min.
	Electrical	100,000 operations min.
Weight		Approx. 12 to 40 g
Inrush current	NC	36 A max.
	NO	36 A max.
Ambient operating temperature		-25 to 80°C (with no icing or condensation)
Ambient operating humidity		35% to 85%RH
Ambient storage temperature		-25 to 80°C (with no icing or condensation)
Degree of protection		IP00
Electric shock protection class		Class II
PTI (proof tracking index)		175
Pollution degree		3 (IEC947-5-1)

* Malfunction within 1 ms

Operating Characteristics

		Output	
Operating characteristics		1	2
Operating force	OF max.	1.96 N	4.90 N
Releasing force	RF min.	0.39 N	0.78 N
Pretravel	PT max.	1.3 mm	1.6 mm

Contact Form

Name	Contact form
Double-throw contacts	

Approved Standard Ratings

- The built-in V-15-1A5 Switch is UL and cUL certified.

Dimensions

Insert one of the following letters into the box (□) in the model number. Refer to Ordering Information for color symbols. (Unit: mm)

VAQ-4□-K



Note: The Operation Unit can be inserted and removed.

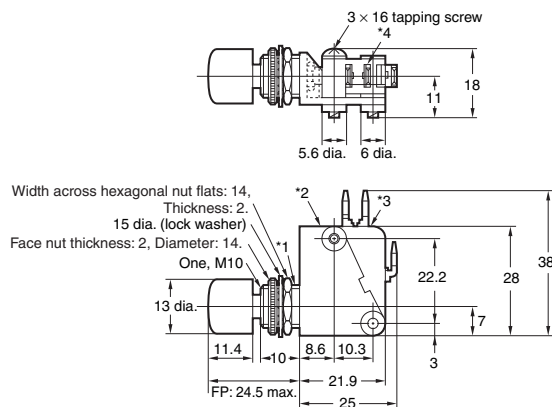

- *1. Unthreaded screw section: Approx. one thread
- *2. Thermoplastic resin foam
- *3. V-15-1A5 Miniature Basic Switch
- *4. Three, #187 tab/solder terminals (t = 0.5)

VAQ-4□-L



Note: The Operation Unit is mounted with M3 screws.

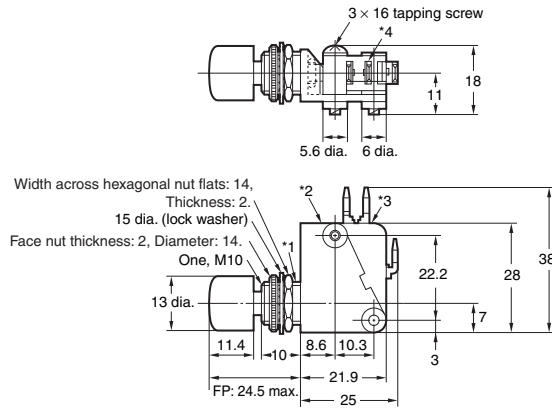

- *1. Unthreaded screw section: Approx. one thread
- *2. Thermoplastic resin foam
- *3. V-15-1A5 Miniature Basic Switch
- *4. Three, #187 tab/solder terminals (t = 0.5)

VAQR-4□

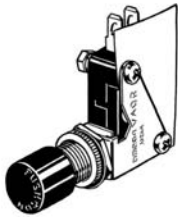

Note: The Operation Unit is mounted with M3 screws.

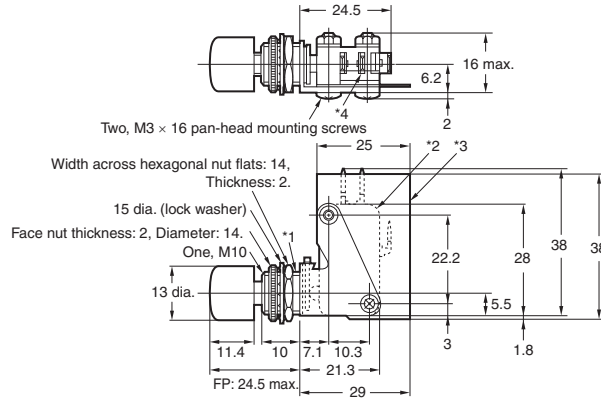

- *1. Unthreaded screw section: Approx. one thread
- *2. V-15-1A5 Miniature Basic Switch
- *3. Separator
- *4. Three, #187 tab/solder terminals (t = 0.5)

2VAQ-4□

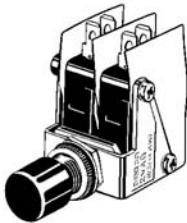

Note: The Operation Unit is mounted with M3 screws.

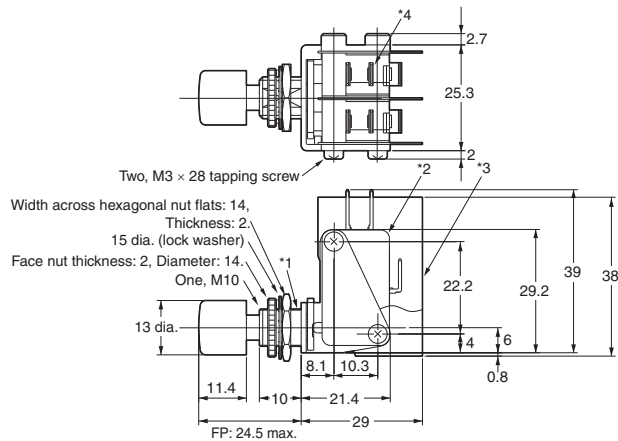

- *1. Unthreaded screw section: Approx. one thread
- *2. Two V-15-1A5 Miniature Basic Switches
- *3. Separator
- *4. Six, #187 tab/solder terminals (t = 0.5)

Panel Cutout

(Unit: mm)



Note: Recommended panel thickness: 1 to 4 mm.

Safety Precautions

Refer to *Safety Precautions for All Pushbutton Switches/Indicators*.

Precautions for Correct Use

Operation Unit Mounting

VAQ-4□-K

- The Operation Unit can be inserted and removed.
- Mounting can be performed by inserting the slit of the Operation Unit into the mounting screw of the Switch.
- Mounting force: 39.2 N max.
- Removing strength: 22.5 N min.

VAQ-4□-L

- The Operation Unit is screwed in.
- Mounting can be performed by inserting the M3 screw of the Operation Unit into the flange of the Switch.
- Tighten the Operation Unit to a torque of 0.20 to 0.39 N·m.

2VAQ-4□

VAQR-4□

- The Operation Unit is screwed in.
- Mounting can be performed by inserting the M3 screw of the Operation Unit into the metal flange of the Switch.
- Tighten the Operation Unit to a torque of 0.20 to 0.39 N·m.

Mounting

- Tighten the nut to a torque of 0.49 to 0.78 N·m.
- Do not perform wiring with power supplied to the Switch. Do not touch the terminals or other charged parts of the Switch while power is being supplied. Doing so may result in electric shock.
- After wiring the Switch, ensure an appropriate insulating distance.

Wiring

- Twist the conductors through the terminal holes before soldering.
- To perform soldering on solder terminals, use a soldering iron with a tip temperature of 250 to 350°C and complete soldering within 5 seconds. Do not exert any external force on the solder during soldering and for one minute after completing soldering.
- For connection with tab terminals, gently insert receptacles for #187 tabs in the terminal push-out direction.
The Switch does not have a ground terminal.

Operation Unit Models

Method Operation Unit color	Insert/remove	Screw-mounted
Blue (A)	VAQ-BA HEAD	VAQ-4A YO HEAD
Black (B)	VAQ-BB HEAD	VAQ-4B YO HEAD
Green (G)	VAQ-BG HEAD	VAQ-4G YO HEAD
Red (R)	VAQ-BR HEAD	VAQ-4R YO HEAD
White (W)	VAQ-BW HEAD	VAQ-4W YO HEAD
Yellow (Y)	VAQ-BY HEAD	VAQ-4Y YO HEAD

Panel Mounting and Operation Unit Mounting

Operation Unit Mounting

VAQ-4□-K

- The Operation Unit can be inserted and removed.
- Mounting can be performed by inserting the slit of the Operation Unit into the mounting screw of the Switch.
- Mounting force: 39.2 N max.
- Removing strength: 22.5 N min.

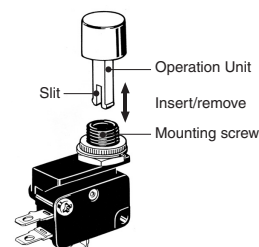

VAQ-4□-L, 2VAQ-4□, VAQR-4□

- The Operation Unit is screwed in.
- Mounting can be performed by inserting the M3 screw of the Operation Unit into the flange of the Switch.
- Tighten the Operation Unit to a torque of 0.20 to 0.39 N·m.

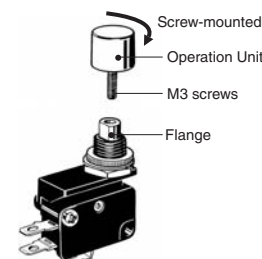

Panel Mounting

Tighten the hexagonal nut using a wrench while securing the Switch by holding it with your fingers.
(Hexagonal nut tightening torque: 0.49 to 0.78 N·m)

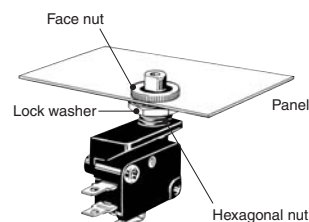

Locking Method

VAQR-□□

- To turn ON the lock, press the Operation Unit and turn it clockwise as indicated at the top of the Operation Unit.
- To release the lock, turn the Operation Unit counterclockwise.

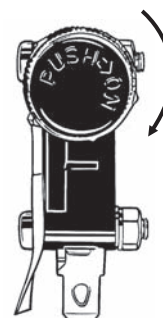

Terms and Conditions Agreement

Read and understand this catalog.

Please read and understand this catalog before purchasing the products. Please consult your OMRON representative if you have any questions or comments.

Warranties.

(a) Exclusive Warranty. Omron's exclusive warranty is that the Products will be free from defects in materials and workmanship for a period of twelve months from the date of sale by Omron (or such other period expressed in writing by Omron). Omron disclaims all other warranties, express or implied.

(b) Limitations. OMRON MAKES NO WARRANTY OR REPRESENTATION, EXPRESS OR IMPLIED, ABOUT NON-INFRINGEMENT, MERCHANTABILITY OR FITNESS FOR A PARTICULAR PURPOSE OF THE PRODUCTS. BUYER ACKNOWLEDGES THAT IT ALONE HAS DETERMINED THAT THE PRODUCTS WILL SUITABLY MEET THE REQUIREMENTS OF THEIR INTENDED USE.

Omron further disclaims all warranties and responsibility of any type for claims or expenses based on infringement by the Products or otherwise of any intellectual property right. (c) Buyer Remedy. Omron's sole obligation hereunder shall be, at Omron's election, to (i) replace (in the form originally shipped with Buyer responsible for labor charges for removal or replacement thereof) the non-complying Product, (ii) repair the non-complying Product, or (iii) repay or credit Buyer an amount equal to the purchase price of the non-complying Product; provided that in no event shall Omron be responsible for warranty, repair, indemnity or any other claims or expenses regarding the Products unless Omron's analysis confirms that the Products were properly handled, stored, installed and maintained and not subject to contamination, abuse, misuse or inappropriate modification. Return of any Products by Buyer must be approved in writing by Omron before shipment. Omron Companies shall not be liable for the suitability or unsuitability or the results from the use of Products in combination with any electrical or electronic components, circuits, system assemblies or any other materials or substances or environments. Any advice, recommendations or information given orally or in writing, are not to be construed as an amendment or addition to the above warranty.

See <http://www.omron.com/global/> or contact your Omron representative for published information.

Limitation on Liability: Etc.

OMRON COMPANIES SHALL NOT BE LIABLE FOR SPECIAL, INDIRECT, INCIDENTAL, OR CONSEQUENTIAL DAMAGES, LOSS OF PROFITS OR PRODUCTION OR COMMERCIAL LOSS IN ANY WAY CONNECTED WITH THE PRODUCTS, WHETHER SUCH CLAIM IS BASED IN CONTRACT, WARRANTY, NEGLIGENCE OR STRICT LIABILITY.

Further, in no event shall liability of Omron Companies exceed the individual price of the Product on which liability is asserted.

Suitability of Use.

Omron Companies shall not be responsible for conformity with any standards, codes or regulations which apply to the combination of the Product in the Buyer's application or use of the Product. At Buyer's request, Omron will provide applicable third party certification documents identifying ratings and limitations of use which apply to the Product. This information by itself is not sufficient for a complete determination of the suitability of the Product in combination with the end product, machine, system, or other application or use. Buyer shall be solely responsible for determining appropriateness of the particular Product with respect to Buyer's application, product or system. Buyer shall take application responsibility in all cases.

NEVER USE THE PRODUCT FOR AN APPLICATION INVOLVING SERIOUS RISK TO LIFE OR PROPERTY OR IN LARGE QUANTITIES WITHOUT ENSURING THAT THE SYSTEM AS A WHOLE HAS BEEN DESIGNED TO ADDRESS THE RISKS, AND THAT THE OMRON PRODUCT(S) IS PROPERLY RATED AND INSTALLED FOR THE INTENDED USE WITHIN THE OVERALL EQUIPMENT OR SYSTEM.

Programmable Products.

Omron Companies shall not be responsible for the user's programming of a programmable Product, or any consequence thereof.

Performance Data.

Data presented in Omron Company websites, catalogs and other materials is provided as a guide for the user in determining suitability and does not constitute a warranty. It may represent the result of Omron's test conditions, and the user must correlate it to actual application requirements. Actual performance is subject to the Omron's Warranty and Limitations of Liability.

Change in Specifications.

Product specifications and accessories may be changed at any time based on improvements and other reasons. It is our practice to change part numbers when published ratings or features are changed, or when significant construction changes are made. However, some specifications of the Product may be changed without any notice. When in doubt, special part numbers may be assigned to fix or establish key specifications for your application. Please consult with your Omron's representative at any time to confirm actual specifications of purchased Product.

Errors and Omissions.

Information presented by Omron Companies has been checked and is believed to be accurate; however, no responsibility is assumed for clerical, typographical or proofreading errors or omissions.