

## SINAMICS G120C compact inverters

0.55 kW to 18.5 kW (0.75 hp to 25 hp)

### SINAMICS G120C compact inverters

#### Overview



SINAMICS G120C frame sizes FSA, FSB and FSC with mounted blanking cover

SINAMICS G120C compact inverters offer a well-balanced combination of features to address a wide range of applications. They are compact, rugged devices that are easy to operate and can be optionally equipped with a basic or advanced operator panel.

SINAMICS G120C inverters are especially suitable when it comes to meeting the requirements of system integrators, OEMs and distributors regarding high productivity and tailored performance.

#### Benefits

- Compact design
- Side-by-side design
- High power density, low envelope dimensions
- Simple installation in the tightest space
- Low space requirement
- Use in small control cabinets, close to the machine
- Optimized parameter set
- Optimized commissioning
- Getting Started document
- BOP-2 or IOP operator panels can be used
- Integrated USB connection
- Simple and fast software parameter assignment
- Simple to use during commissioning and in operation
- Minimized training costs, existing SINAMICS know-how can be used
- High degree of service friendliness, simple maintenance
- Plug-in terminals
- Cloning function using BOP-2, IOP or memory card
- Operating hours counter for "drive on" and "motor on"
- Fast mechanical installation
- Intuitive standard commissioning
- Component of Totally Integrated Automation
- Energy-efficient, sensorless vector control
- Automatic flux reduction with V/f ECO
- Integrated energy saving computer
- Safety Integrated (STO)
- Communications versions with PROFINET / EtherNet/IP, PROFIBUS DP, CANopen, USS/Modbus RTU
- Coated modules
- Operation up to an ambient temperature of 60 °C (140 °F)

#### Design

SINAMICS G120C is a compact inverter for control cabinet mounting in IP20 degree of protection where the Control Unit (CU) and Power Module (PM) function units are combined in one device.

The compact mechanical design and the high power density allow these devices to be installed in machine control enclosures and control cabinets for maximum space utilization. The SINAMICS G120C compact inverter can be butt-mounted directly, without derating; the PROFINET version can be butt-mounted up to 55 °C (131 °F).



SINAMICS G120C, frame size FSB, with BOP-2

SINAMICS G120C can be integrated into the widest range of applications, either using the integrated digital and analog inputs or via the integrated fieldbus interface (available in the USS, Modbus RTU, PROFIBUS, PROFINET / EtherNet/IP, CANopen versions). Especially the product versions with integrated PROFIBUS/PROFINET interface make full integration into the Siemens TIA family possible, therefore allowing the advantages of the seamless TIA product family to be fully utilized. SINAMICS G120C drives are preset in the factory so that they can be immediately connected to PROFIBUS, PROFINET or CANopen fieldbus systems and used without parameterization.

SINAMICS G120C is also equipped with the safety function STO (Safe Torque Off) as standard, which is used to safely stop drives. As a consequence, machine manufacturers can simply comply with current machinery directives with minimum associated costs.

SINAMICS G120C can control asynchronous (induction) motors in the power range from 0.37 kW up to 18.5 kW (0.5 hp up to 25 hp). Reliable and efficient motor operation is achieved by using state-of-the-art IGBT technology combined with vector control. The extensive range of functions integrated in the SINAMICS G120C also offers a high degree of protection for the inverter and motor.

#### Line-side components

##### Line reactors

Line reactors smooth the current drawn by the inverter and thus reduce harmonic components in the line current. Through the reduction of the current harmonics, the thermal load on the power components in the rectifier and in the DC-link capacitors is reduced as well as the harmonic effects on the supply. The use of a line reactor increases the service life of the inverter.

##### Recommended line-side power components

Standard fuses can be used for the SINAMICS G120C. These must be dimensioned to comply with local regulations. In this chapter, you will find recommended components such as fuses and circuit breakers in compliance with IEC and UL regulations.

## SINAMICS G120C compact inverters

0.55 kW to 18.5 kW (0.75 hp to 25 hp)

### SINAMICS G120C compact inverters

#### Design

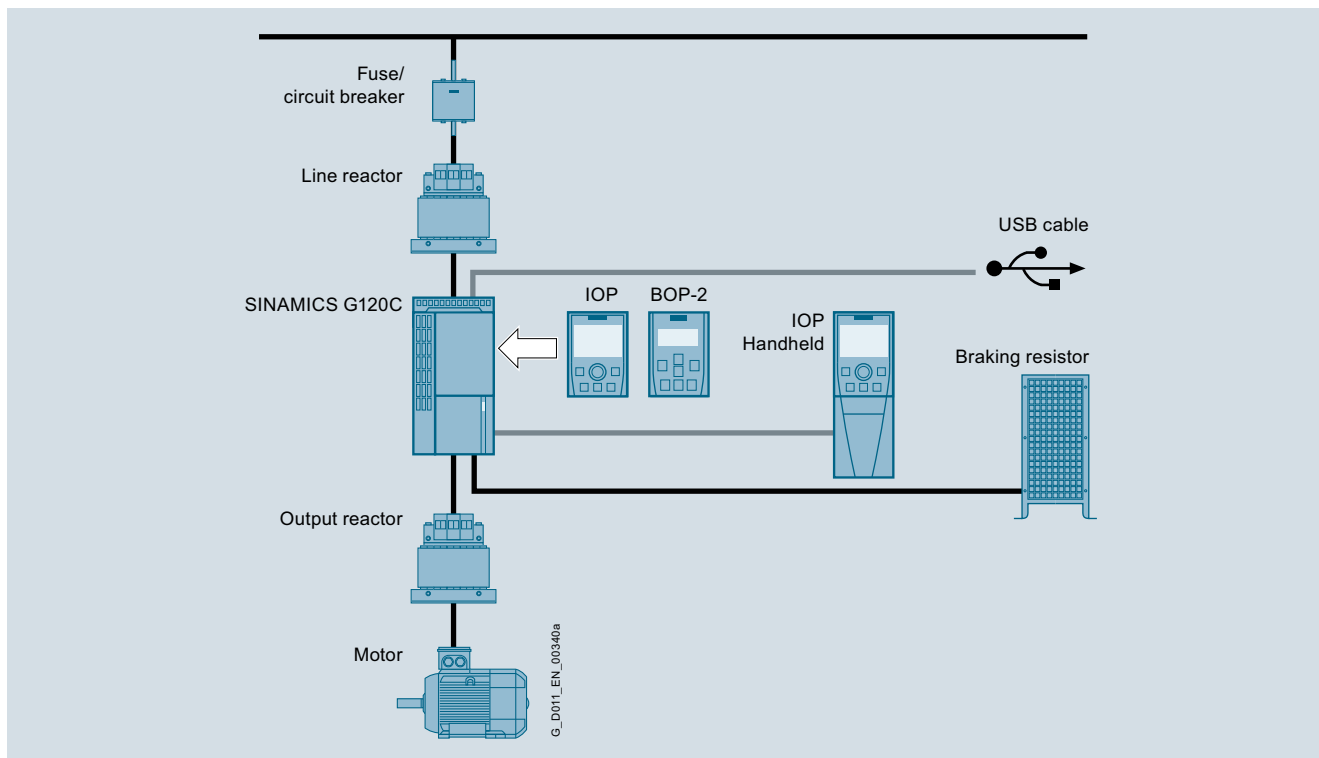

#### DC link components

##### Braking resistors

The excess energy of the DC link is dissipated using the braking resistor. The braking resistors are designed for use with the SINAMICS G120C. This has an integrated brake chopper (electronic switch).

#### Load-side power components

##### Output reactors

Output reactors reduce the rate of voltage rise (dv/dt) and the height of the current peaks, and enable longer motor cables to be connected.

#### Supplementary system components

##### Intelligent Operator Panel IOP

Graphics-based, user-friendly and powerful operator panel for commissioning and diagnostics as well as local operator control and monitoring of SINAMICS G120C.

##### Basic Operator Panel BOP-2

A 2-line display to provide support when commissioning and troubleshooting the drive. The drive can be locally controlled.

##### Memory card

The parameter settings for an inverter can be stored on the SINAMICS SD memory card. When service is required, e.g. after the inverter has been replaced and the data have been downloaded from the memory card the drive system is immediately ready for use again. The associated memory card holder is integrated in the inverter.

##### PC inverter connection kit 2

For controlling and commissioning an inverter directly from a PC if the STARTER commissioning tool or SINAMICS Startdrive has been installed on the PC.

#### Spare parts

##### Shield plates

A set of shield plates is included in the scope of delivery for the motor and signal cables corresponding to the frame size of the SINAMICS G120C, and can also be ordered as spare parts.

##### Spare Parts Kit

This kit comprises 5 sets of I/O terminals, 1 RS485 terminal, 2 pairs of Control Unit doors (1 × PN and 1 × other communication versions) and 1 blanking cover.

##### Set of connectors

A set of connectors for the line feeder cable, braking resistor and motor cable can be ordered corresponding to the frame size of the SINAMICS G120C inverter.

##### Roof-mounted fan

A roof-mounted fan (at the top of the device) comprising a pre-assembled unit with holder and fan can be ordered corresponding to the frame size of the SINAMICS G120C.

##### Fan unit

A replacement fan (at the rear of the device; heat sink) comprising a pre-assembled unit with holder and fan can be ordered corresponding to the frame size of the SINAMICS G120C.

## Configuration

The following electronic configuring guides and engineering tools are available for SINAMICS G120C compact inverters:

### **Drive Technology Configurator (DT Configurator) within the CA 01**

The interactive catalog CA 01 – the offline Industry mall of Siemens on DVD-ROM – contains over 100,000 products with approximately 5 million possible drive system product variants. The Drive Technology Configurator (DT Configurator) has been developed to facilitate selection of the correct motor and/or inverter from the wide spectrum of drives. It is integrated as a selection tool in Catalog CA 01.

### **Online DT Configurator**

In addition, the DT Configurator can now be used on the Internet without requiring any installation. The DT Configurator can be found in the Siemens Industry Mall at the following address:  
[www.siemens.com/dt-configurator](http://www.siemens.com/dt-configurator)

### **SIZER for Siemens Drives engineering tool**

The SIZER for Siemens Drives engineering tool makes it easy to engineer the SINAMICS and MICROMASTER 4 drive families. It provides support when selecting the hardware and firmware components necessary to implement a drive task. SIZER for Siemens Drives covers the full range of operations required to configure a complete drive system.

You can find further information on SIZER for Siemens Drives in the section [Engineering Tools](#).

The SIZER for Siemens Drives engineering tool is available free of charge on the internet at [www.siemens.com/sizer](http://www.siemens.com/sizer)

### **STARTER commissioning tool**

The STARTER commissioning tool allows menu-prompted commissioning, optimization and diagnostics. Apart from the SINAMICS drives, STARTER is also suitable for MICROMASTER 4 devices.

You can find further information on the STARTER commissioning tool in the section [Engineering Tools](#).

Additional information on the STARTER commissioning tool is available on the internet at [www.siemens.com/starter](http://www.siemens.com/starter)

### **SINAMICS Startdrive commissioning tool**

SINAMICS Startdrive is a tool for configuring, commissioning, and diagnosing the SINAMICS family of drives and is integrated into the TIA Portal. SINAMICS Startdrive can be used to implement drive tasks with the SINAMICS G120, SINAMICS G120C, SINAMICS G110M (SINAMICS Startdrive V13 and higher), SINAMICS G120D and SINAMICS G120P (SINAMICS Startdrive V13 and higher) inverter series. The commissioning tool has been optimized with regard to user friendliness and consistent use of the TIA Portal benefits of a common working environment for PLC, HMI and drives.

You can find further information on the SINAMICS Startdrive commissioning tool in the section [Engineering Tools](#).

The SINAMICS Startdrive commissioning tool is available free of charge on the internet at [www.siemens.com/startdrive](http://www.siemens.com/startdrive)

### **Drive ES engineering system**

Drive ES is the engineering system that can be used to integrate the communication, configuration and data management functions of Siemens drive technology into the SIMATIC automation world easily, efficiently and cost-effectively. The STEP 7 Manager user interface provides the ideal basis for this. A variety of software packages are available for SINAMICS – Drive ES Basic, Drive ES SIMATIC and Drive ES PCS.

You can find further information on the Drive ES engineering system in the section [Engineering Tools](#).

Additional information on the DRIVE ES engineering system is available on the internet at [www.siemens.com/drive-es](http://www.siemens.com/drive-es)

## SINAMICS G120C compact inverters

0.55 kW to 18.5 kW (0.75 hp to 25 hp)

### SINAMICS G120C compact inverters

#### Selection and ordering data

The article number is selected corresponding to

- the required motor power or the motor current required and the overload requirements of the application,
- the necessary EMC classification and
- the required integrated fieldbus interface

| Rated power <sup>1)</sup> |      | Base-load current $I_L$ <sup>2)</sup><br>A | Base-load current $I_H$ <sup>3)</sup><br>A | Frame size | Version               | SINAMICS G120C<br>without line filter | SINAMICS G120C<br>with integrated line filter<br>class A |
|---------------------------|------|--|--|------------|-----------------------|---------------------------------------|--|
| kW                        | hp   |  |  |            |                       | Article No.                           | Article No.  |
| <b>380 ... 480 V 3 AC</b> |      |  |  |            |                       |                                       |  |
| 0.55                      | 0.75 | 1.7  | 1.3  | FSA        | USS, Modbus RTU       | <b>6SL3210-1KE11-8UB1</b>             | <b>6SL3210-1KE11-8AB1</b>                                |
|                           |      |  |  |            | PROFIBUS DP           | <b>6SL3210-1KE11-8UP1</b>             | <b>6SL3210-1KE11-8AP1</b>                                |
|                           |      |  |  |            | PROFINET, EtherNet/IP | <b>6SL3210-1KE11-8UF1</b>             | <b>6SL3210-1KE11-8AF1</b>                                |
|                           |      |  |  |            | CANopen               | <b>6SL3210-1KE11-8UC1</b>             | <b>6SL3210-1KE11-8AC1</b>                                |
| 0.75                      | 1    | 2.2  | 1.7  | FSA        | USS, Modbus RTU       | <b>6SL3210-1KE12-3UB1</b>             | <b>6SL3210-1KE12-3AB1</b>                                |
|                           |      |  |  |            | PROFIBUS DP           | <b>6SL3210-1KE12-3UP1</b>             | <b>6SL3210-1KE12-3AP1</b>                                |
|                           |      |  |  |            | PROFINET, EtherNet/IP | <b>6SL3210-1KE12-3UF1</b>             | <b>6SL3210-1KE12-3AF1</b>                                |
|                           |      |  |  |            | CANopen               | <b>6SL3210-1KE12-3UC1</b>             | <b>6SL3210-1KE12-3AC1</b>                                |
| 1.1                       | 1.5  | 3.1  | 2.2  | FSA        | USS, Modbus RTU       | <b>6SL3210-1KE13-2UB1</b>             | <b>6SL3210-1KE13-2AB1</b>                                |
|                           |      |  |  |            | PROFIBUS DP           | <b>6SL3210-1KE13-2UP1</b>             | <b>6SL3210-1KE13-2AP1</b>                                |
|                           |      |  |  |            | PROFINET, EtherNet/IP | <b>6SL3210-1KE13-2UF1</b>             | <b>6SL3210-1KE13-2AF1</b>                                |
|                           |      |  |  |            | CANopen               | <b>6SL3210-1KE13-2UC1</b>             | <b>6SL3210-1KE13-2AC1</b>                                |
| 1.5                       | 2    | 4.1  | 3.1  | FSA        | USS, Modbus RTU       | <b>6SL3210-1KE14-3UB1</b>             | <b>6SL3210-1KE14-3AB1</b>                                |
|                           |      |  |  |            | PROFIBUS DP           | <b>6SL3210-1KE14-3UP1</b>             | <b>6SL3210-1KE14-3AP1</b>                                |
|                           |      |  |  |            | PROFINET, EtherNet/IP | <b>6SL3210-1KE14-3UF1</b>             | <b>6SL3210-1KE14-3AF1</b>                                |
|                           |      |  |  |            | CANopen               | <b>6SL3210-1KE14-3UC1</b>             | <b>6SL3210-1KE14-3AC1</b>                                |
| 2.2                       | 3    | 5.6  | 4.1  | FSA        | USS, Modbus RTU       | <b>6SL3210-1KE15-8UB1</b>             | <b>6SL3210-1KE15-8AB1</b>                                |
|                           |      |  |  |            | PROFIBUS DP           | <b>6SL3210-1KE15-8UP1</b>             | <b>6SL3210-1KE15-8AP1</b>                                |
|                           |      |  |  |            | PROFINET, EtherNet/IP | <b>6SL3210-1KE15-8UF1</b>             | <b>6SL3210-1KE15-8AF1</b>                                |
|                           |      |  |  |            | CANopen               | <b>6SL3210-1KE15-8UC1</b>             | <b>6SL3210-1KE15-8AC1</b>                                |
| 3                         | 4    | 7.3  | 5.6  | FSA        | USS, Modbus RTU       | <b>6SL3210-1KE17-5UB1</b>             | <b>6SL3210-1KE17-5AB1</b>                                |
|                           |      |  |  |            | PROFIBUS DP           | <b>6SL3210-1KE17-5UP1</b>             | <b>6SL3210-1KE17-5AP1</b>                                |
|                           |      |  |  |            | PROFINET, EtherNet/IP | <b>6SL3210-1KE17-5UF1</b>             | <b>6SL3210-1KE17-5AF1</b>                                |
|                           |      |  |  |            | CANopen               | <b>6SL3210-1KE17-5UC1</b>             | <b>6SL3210-1KE17-5AC1</b>                                |
| 4                         | 5    | 8.8  | 7.3  | FSA        | USS, Modbus RTU       | <b>6SL3210-1KE18-8UB1</b>             | <b>6SL3210-1KE18-8AB1</b>                                |
|                           |      |  |  |            | PROFIBUS DP           | <b>6SL3210-1KE18-8UP1</b>             | <b>6SL3210-1KE18-8AP1</b>                                |
|                           |      |  |  |            | PROFINET, EtherNet/IP | <b>6SL3210-1KE18-8UF1</b>             | <b>6SL3210-1KE18-8AF1</b>                                |
|                           |      |  |  |            | CANopen               | <b>6SL3210-1KE18-8UC1</b>             | <b>6SL3210-1KE18-8AC1</b>                                |
| 5.5                       | 7.5  | 12.5                                       | 8.8  | FSB        | USS, Modbus RTU       | <b>6SL3210-1KE21-3UB1</b>             | <b>6SL3210-1KE21-3AB1</b>                                |
|                           |      |  |  |            | PROFIBUS DP           | <b>6SL3210-1KE21-3UP1</b>             | <b>6SL3210-1KE21-3AP1</b>                                |
|                           |      |  |  |            | PROFINET, EtherNet/IP | <b>6SL3210-1KE21-3UF1</b>             | <b>6SL3210-1KE21-3AF1</b>                                |
|                           |      |  |  |            | CANopen               | <b>6SL3210-1KE21-3UC1</b>             | <b>6SL3210-1KE21-3AC1</b>                                |
| 7.5                       | 10   | 16.5                                       | 12.5                                       | FSB        | USS, Modbus RTU       | <b>6SL3210-1KE21-7UB1</b>             | <b>6SL3210-1KE21-7AB1</b>                                |
|                           |      |  |  |            | PROFIBUS DP           | <b>6SL3210-1KE21-7UP1</b>             | <b>6SL3210-1KE21-7AP1</b>                                |
|                           |      |  |  |            | PROFINET, EtherNet/IP | <b>6SL3210-1KE21-7UF1</b>             | <b>6SL3210-1KE21-7AF1</b>                                |
|                           |      |  |  |            | CANopen               | <b>6SL3210-1KE21-7UC1</b>             | <b>6SL3210-1KE21-7AC1</b>                                |
| 11                        | 15   | 25   | 16.5                                       | FSC        | USS, Modbus RTU       | <b>6SL3210-1KE22-6UB1</b>             | <b>6SL3210-1KE22-6AB1</b>                                |
|                           |      |  |  |            | PROFIBUS DP           | <b>6SL3210-1KE22-6UP1</b>             | <b>6SL3210-1KE22-6AP1</b>                                |
|                           |      |  |  |            | PROFINET, EtherNet/IP | <b>6SL3210-1KE22-6UF1</b>             | <b>6SL3210-1KE22-6AF1</b>                                |
|                           |      |  |  |            | CANopen               | <b>6SL3210-1KE22-6UC1</b>             | <b>6SL3210-1KE22-6AC1</b>                                |
| 15                        | 20   | 31   | 25   | FSC        | USS, Modbus RTU       | <b>6SL3210-1KE23-2UB1</b>             | <b>6SL3210-1KE23-2AB1</b>                                |
|                           |      |  |  |            | PROFIBUS DP           | <b>6SL3210-1KE23-2UP1</b>             | <b>6SL3210-1KE23-2AP1</b>                                |
|                           |      |  |  |            | PROFINET, EtherNet/IP | <b>6SL3210-1KE23-2UF1</b>             | <b>6SL3210-1KE23-2AF1</b>                                |
|                           |      |  |  |            | CANopen               | <b>6SL3210-1KE23-2UC1</b>             | <b>6SL3210-1KE23-2AC1</b>                                |
| 18.5                      | 25   | 37   | 31   | FSC        | USS, Modbus RTU       | <b>6SL3210-1KE23-8UB1</b>             | <b>6SL3210-1KE23-8AB1</b>                                |
|                           |      |  |  |            | PROFIBUS DP           | <b>6SL3210-1KE23-8UP1</b>             | <b>6SL3210-1KE23-8AP1</b>                                |
|                           |      |  |  |            | PROFINET, EtherNet/IP | <b>6SL3210-1KE23-8UF1</b>             | <b>6SL3210-1KE23-8AF1</b>                                |
|                           |      |  |  |            | CANopen               | <b>6SL3210-1KE23-8UC1</b>             | <b>6SL3210-1KE23-8AC1</b>                                |

<sup>1)</sup> The rated power of the device based on the rated output current  $I_L$  and a rated input voltage of 400 V 3 AC. The rated power is specified on the device rating plate.

<sup>2)</sup> The base-load current  $I_L$  is based on the duty cycle for low overload (LO). The current value is specified on the device rating plate.

<sup>3)</sup> The base-load current  $I_H$  is based on the duty cycle for high overload (HO). The current value is not specified on the device rating plate.

# SINAMICS G120C compact inverters

0.55 kW to 18.5 kW (0.75 hp to 25 hp)

## SINAMICS G120C compact inverters

### Technical specifications

Unless explicitly specified otherwise, the following technical specifications are valid for all SINAMICS G120C compact inverters.

| Mechanical specifications                                    |   |
|--|---|
| <b>Vibratory load</b>  |   |
| • Transport acc. to EN 60721-3-2 <sup>1)</sup>               | Class 1M2   |
| • Operation acc. to EN 60721-3-3                             | Class 3M2   |
| <b>Shock load</b>  |   |
| • Transport acc. to EN 60721-3-2 <sup>1)</sup>               | Class 1M2   |
| • Operation acc. to EN 60721-3-3                             | Class 3M2   |
| <b>Degree of protection</b>                                  | IP20/ UL open type  |
| <b>Permissible mounting position</b>                         | Vertical wall mounting  |
| Ambient conditions   |   |
| <b>Protection class</b><br>according to EN 61800-5-1         | Class III (PELV1)   |
| <b>Touch protection</b><br>according to EN 61800-5-1         | Class I (with protective conductor system)  |
| <b>Humidity, max.</b>  | 95 % at 40 °C (104 °F), condensation and icing not permissible  |
| <b>Ambient temperature</b>                                   |   |
| • Storage <sup>1)</sup> acc. to EN 60068-2-1                 | -40 ... +70 °C (-40 ... +158 °F)  |
| • Transport <sup>1)</sup> acc. to EN 60068-2-1               | -40 ... +70 °C (-40 ... +158 °F)  |
| • Operation acc. to EN 60068-2-2                             | -10 ... +40 °C (14 ... 104 °F) without derating<br>>40 ... 60 °C (104 ... 140 °F) <a href="#">see derating characteristics</a>  |
| <b>Environmental class in operation</b>                      |   |
| • Harmful chemical substances                                | Class 3C2 to EN 60721-3-3   |
| • Organic/biological pollutants                              | Class 3B1 to EN 60721-3-3   |
| • Degree of pollution  | 2 acc. to EN 61800  |
| Standards  |   |
| <b>Compliance with standards</b>                             | CE, cULus, C-Tick   |
| <b>Fail-safe certification</b>                               | Function: Safe Torque Off (STO)   |
| • According to IEC 61508                                     | SIL 2   |
| • According to EN ISO 13849-1                                | PL d and Category 3   |
| <b>CE marking, according to</b>                              | EMC Directive 2004/108/EC<br>Low-Voltage Directive 2006/95/EC   |
| <b>EMC behavior <sup>2)</sup></b><br>According to EN 61800-3 |   |
| <u>Interference immunity</u>                                 | The SINAMICS G120C compact inverters are tested with the interference immunity requirements for environments according to Category C3.  |
| <u>Interference emissions</u>                                |   |
| • Frame sizes FSA to FSC without integrated line filter      | <sup>3)</sup>   |
| • Frame sizes FSA to FSC with integrated line filter class A | The inverters comply with the limits values according to Category C3.<br>The inverters comply with the limits values for conducted interferences and field-conducted radiated interferences according to Category C2. <sup>4) 5)</sup>  |
|  | <b>Note:</b><br>The EMC product standard EN 61800-3 does not apply directly to a frequency inverter but to a PDS (Power Drive System), which comprises the complete circuitry, motor and cables in addition to the inverter. The frequency inverters on their own do not generally require identification according to the EMC Directive. |

<sup>1)</sup> In transport packaging.

<sup>2)</sup> For further general information, [see also chapter SINAMICS G120, section Technical specifications, Compliance with standards.](#)

<sup>3)</sup> Non-filtered devices are designed for operation on IT systems or in conjunction with an RCD. The customer must provide suitable RI suppression equipment to ensure that these devices comply with the limits defined for Category C3 or C2.

<sup>4)</sup> With shielded motor cable up to 25 m (82 ft).

<sup>5)</sup> SINAMICS G120C compact inverters frame size FSB with PROFINET interface (Article-No.: 6SL3210-1KE21-.AF1) additionally need a line reactor.